

SRT High Pressure Fuel Pump Kit

by Suter Racing Technology

For Superbike Racing Use

The SRT HP Fuel Pump kit for the Superbike class provides the basis for a 10 bar fuel system. All required components such as high-flow/high pressure fuel pump, pressure regulator and filters are included in a compact assembly.

With an increase of fuel injection pressure, the fuel droplet size decreases and the location of maximum droplet size appears farther downstream than in the case of low injection pressure. Since distribution of fuel to air becomes better during ignition period, the engine performance can be increased.

- Marelli MotoGP Gear Fuel Pump with limited Current Absorption
- Marelli 10bar Pressure Regulator
- Fuel Pre-Pump Filter and Fine Filter after Pump (10 microns)
- JIC-06 Fuel Connector to fit high flow Fuel Lines
- Housing, connectors etc. made from high-strength T-6 Aircraft quality Aluminum
- Small overall size

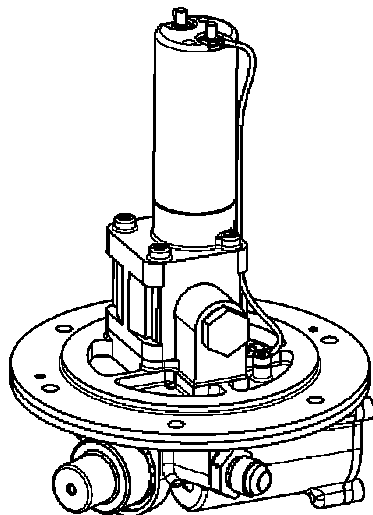

Price of the **SRT HP Fuel Pump**: 5900 € (excl. VAT)
SRT Art. No: 041-19006

Designed to fit into a Honda CBR 1000 fuel tank, we also provide the possibility to adapt this kit to other bike types. Please ask us for a special offer.

For customers interested in setting up a whole fuel system, we also provide a corresponding fuel rail kit with high-end Marelli fuel injectors. As well, please ask us for a special offer resp. contact us with your specific needs.

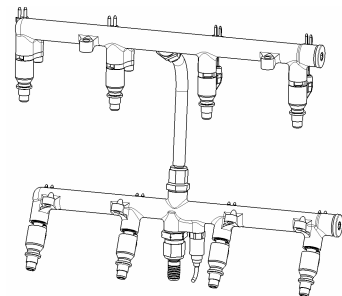

Please place orders by FAX or E-Mail to:

Suter Racing Technology AG, Mettlenstrasse 3, 8488 Turbenthal, Switzerland

Tel. +41/(0)52 397 10 60, Fax. +41/(0)52 397 10 70, www.suterracing.com / srt@suterracing.com